



# Quality Hydraulic Steering Systems

*New models for larger and twin outboard installations*

**NEW**



*Great steering upgrade for cuddy cabs, centre consoles and RIBs*



*Quality steering solutions for twin rig outboard installations*

# What's in a Kit?

Each kit contains a helm pump with fittings, cylinder with fittings, twin hose set with fittings, one litre of hydraulic oil and an easy filling oil system.

*Pump made from full block hardened aluminium*

*Cylinder made from cold drawn, hardened aluminium*

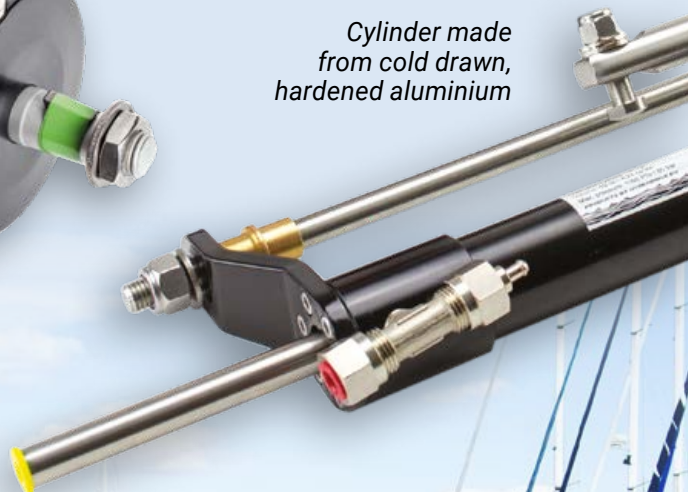

**OUTBOARD HYDRAULIC STEERING SYSTEM**  
75HP - 90 HP - 120 HP - 150 HP

- Complete kit, all included
- The housing of pump made from hot pressing hardened aluminium
- High anodised preventing corrosion
- High precision
- High quality products
- Completely produced in Europe

**HIGH QUALITY**

[www.hydrodrive.eu](http://www.hydrodrive.eu)

MF115-MRA MF90-W MF155-W

# Replace your mechanical cable steering

Cable steering systems require higher maintenance and performance can diminish over time. Hydrodrive makes upgrading your existing mechanical system to smooth hydraulic steering easy.

Hydrodrive is the perfect hydraulic steering system for single outboards up to 350HP or 300 + 300HP twin outboard installations.

# European Made, Quality Manufacture

Hydrodrive is manufactured in Hungary by Techno Italia Ltd. Adopting robust material used in the aircraft industry has resulted in the development of a strong, reliable and high quality hydraulic steering range.

CE Made in EU  
ISO 10592





For smaller boats  
with outboards

# MF75W & MF90W

For outboards up to 75HP and 90HP



UP TO  
**75HP  
& 90HP**

## SPECIFICATIONS

	MF75W	MF90W
AMI Code	* 0210075	* 0210090
Engine Power (Max)	75HP	90HP
Output Force	220Kg	236Kg
Torque	46 Kgf	51 Kgf
Max Speed	30 Kts	35 Kts
Turns	4.4	4.5
Lock Valve	No	No
Cylinder	MC75W 68cc 202mm stroke	MC90W 70cc 210mm stroke
Hose Set	Twin 4.0m + 4.0m (13')	Twin 4.5m + 4.5m (14.5')
Autopilot Capable	No	No

Kits Include 1L of Hydraulic Oil. No steering wheel included. **\*No Engine Arm.**

**Customers Please Note:** Suzuki Outboards may require the purchase of Extension Adaptors.

- Extremely easy to install
- Pump made from full block hardened aluminium
- Cylinder made from cold drawn, hardened aluminium
- High pressure Hose Set (1700 PSI - 120 bar)
- Universal application for all types of engines

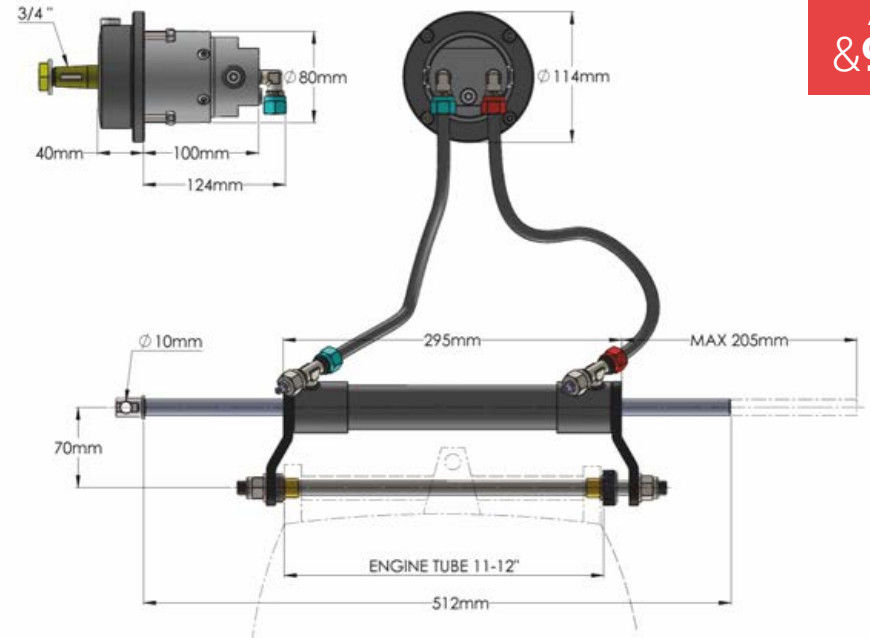

## TL1-16 flush mount

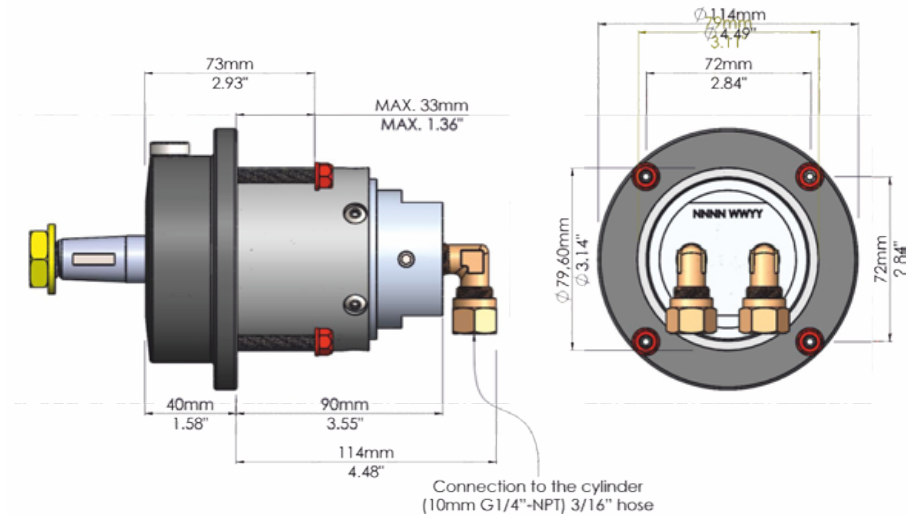

MF75W



MF90W



# MF115MRA

For outboards up to 120HP



UP TO  
120HP

SPECIFICATIONS	
AMI Code	0210115
Supplier Code	MF115MRA
Engine Power (Max)	120HP
Output Force	236Kg
Torque	51 Kgf
Max Speed	50 Kts
Turns	4.5
Lock Valve	Yes
Cylinder	MC115W 71cc 210mm stroke
Hose Set	Twin 5.0m + 5.0m (16')
Autopilot Capable	Yes

Kits Include 1L of Hydraulic Oil. No steering wheel included. **Customers Please Note:** Suzuki Outboards may require the purchase of Extension Adaptors.

## Built in non feedback valve Automatic Pilot Connection Port

- Extremely easy to install
- Pump made from full block hardened aluminium
- Cylinder made from cold drawn, hardened aluminium
- High pressure Hose Set (1700 PSI - 120 bar)
- Universal application for all types of engines

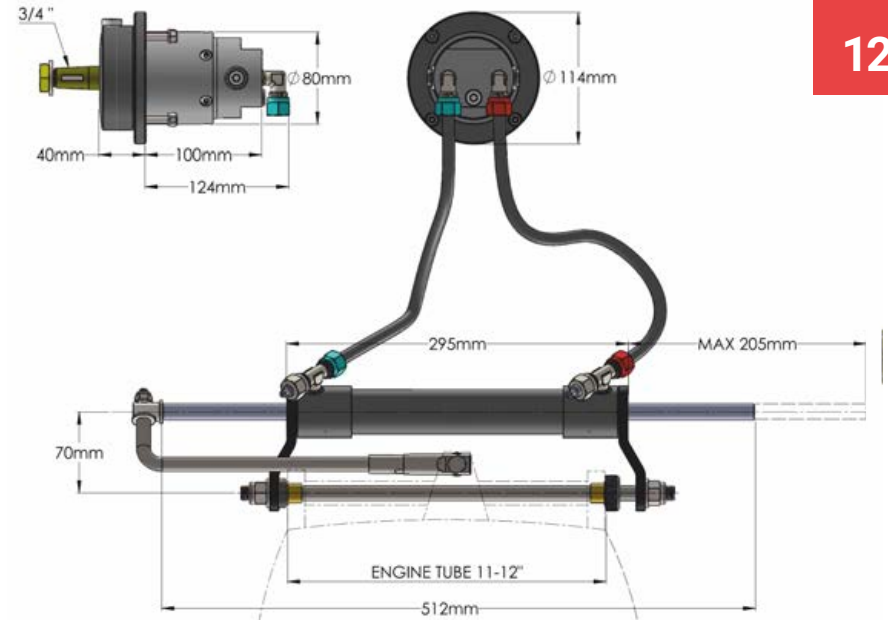

## TL1-16MRA flush mount

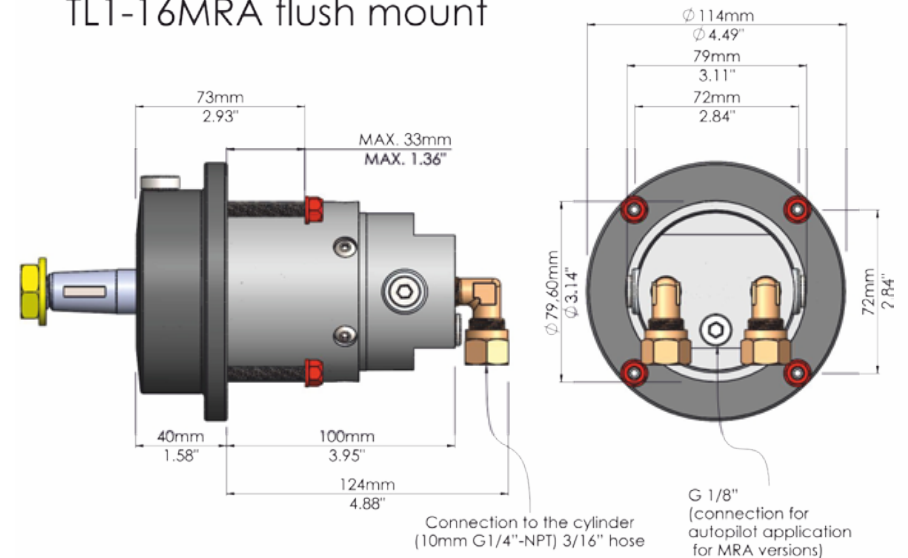

# MF175W

For outboards up to 175HP



UP TO  
175HP

SPECIFICATIONS	
AMI Code	0210154
Supplier Code	MF175W
Engine Power (Max)	175HP
Output Force	290 Kgf
Torque	60 Kgm
Max Speed	55 Kts
Turns	5.4
Lock Valve	Yes
Cylinder	MC175-W 86cc 208mm stroke
Hose Set	Twin 6.0m + 6.0m (19.5')
Autopilot Capable	Yes

Kits Include 2L of Hydraulic Oil. No steering wheel included. Engine Arm, universal application.  
**Customers Please Note:** Suzuki Outboards may require the purchase of Extension Adaptors.

## Built in non feedback valve Automatic Pilot Connection Port

- Extremely easy to install
- Pump made from full block hardened aluminium
- Cylinder made from cold drawn, hardened aluminium
- High pressure Hose Set (1700 PSI - 120 bar)
- Universal application for all types of engines

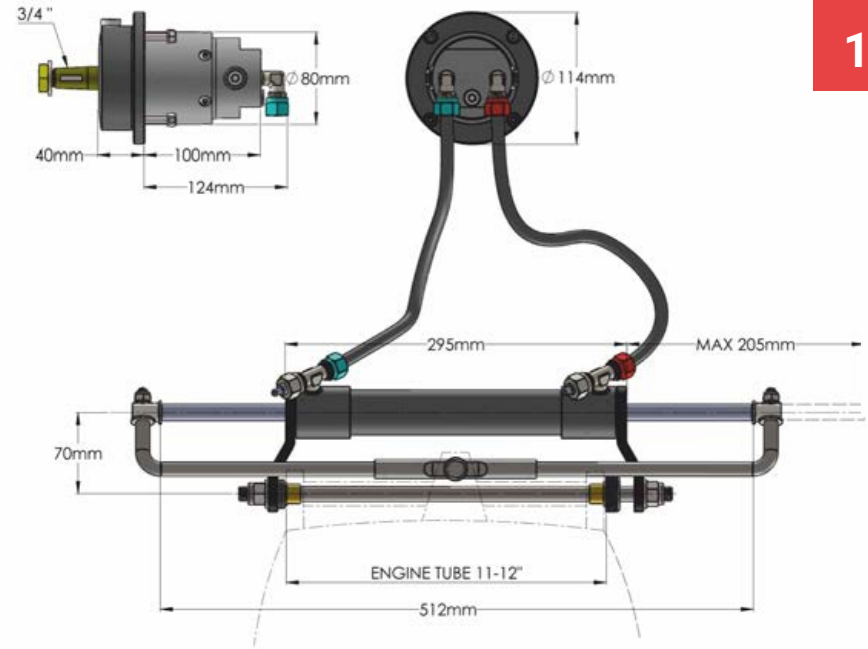

## TL1-16MRA flush mount

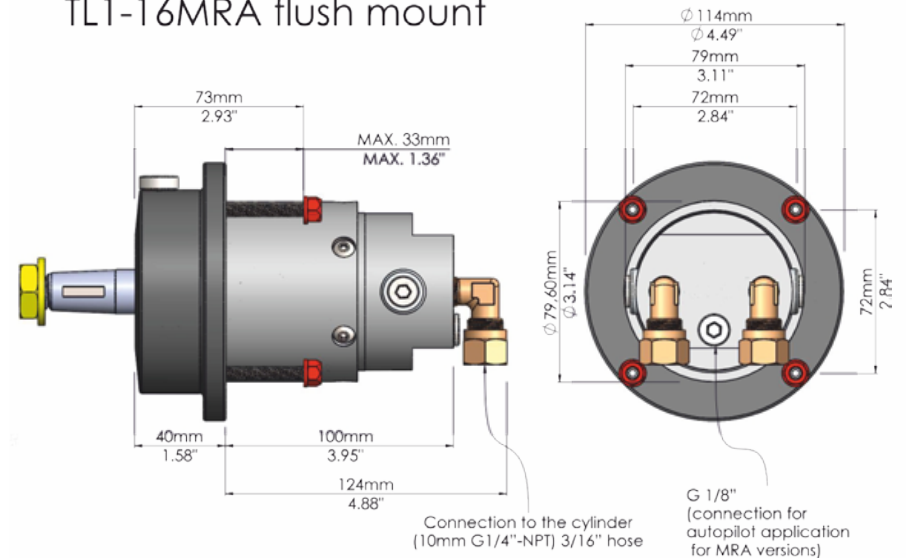



For larger boats  
with outboards

**NEW**

# MF255WTS

For outboards up to 250HP



UP TO  
**250HP**  
NEW

SPECIFICATIONS	
AMI Code	0210157
Supplier Code	MF255WTS
Engine Power (Max)	250HP
Output Force	422Kgf
Torque	88 Kgm
Max Speed	55 Kts
Turns	4.5
Lock Valve	Yes
Cylinder	MC255-WTS 125cc 206mm stroke
Hose Set	Twin 6.0m + 6.0m (19.5')
Autopilot Capable	Yes
Kits Include 2L of Hydraulic Oil. No steering wheel included. New easy mounting system.	

## Built in non feedback valve Automatic Pilot Connection Port

- Extremely easy to install
- Compact bullhorn mount
- Pump made from full block hardened aluminium
- Cylinder made from cold drawn, hardened aluminium
- High pressure Hose Set (1700 PSI - 120 bar)
- Universal application for all types of engines

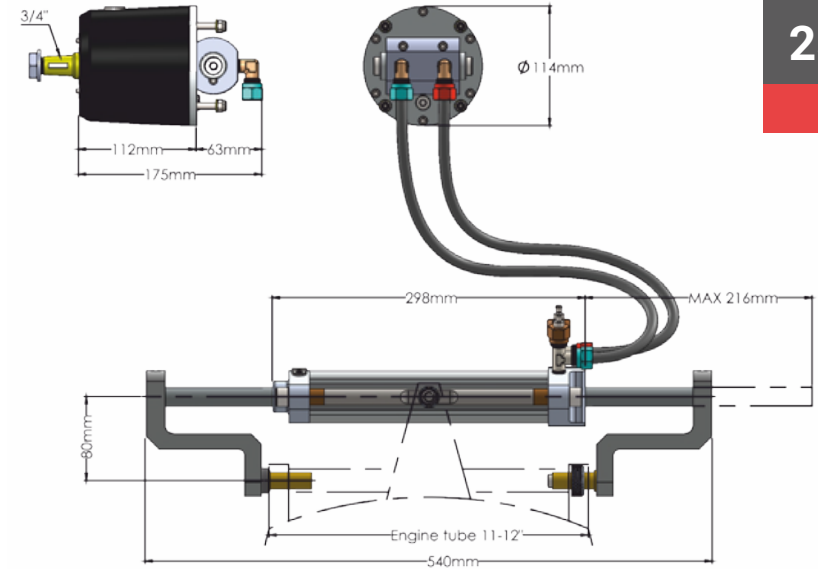

## Pump: TL2 Front mounting

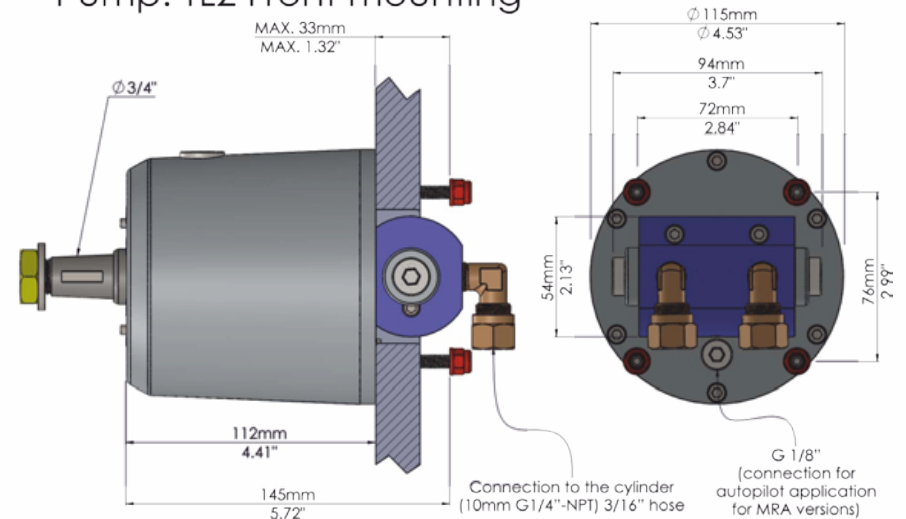



# MF350W

For outboards up to 350HP



SPECIFICATIONS	
AMI Code	0210156
Supplier Code	MF350W
Engine Power (Max)	350HP
Output Force	495 Kgf
Torque	102 Kgm
Max Speed	60 Kts
Turns	5.2
Lock Valve	Yes
Cylinder	MC350-W 146cc 206mm stroke
Hose Set	Twin 7.0m + 7.0m (23')
Autopilot Capable	Yes
Kits Include 2L of Hydraulic Oil. No steering wheel included. New Stainless Steel Twin Engine Arm included.	

## Built in non feedback valve Automatic Pilot Connection Port

- Extremely easy to install
- Pump made from full rod hardened aluminium
- Universal application for all types of engines
- Stainless Steel fixing brackets
- Cylinder made from cold drawn, hardened aluminium
- High pressure Hose Set (1700 PSI - 120 bar)

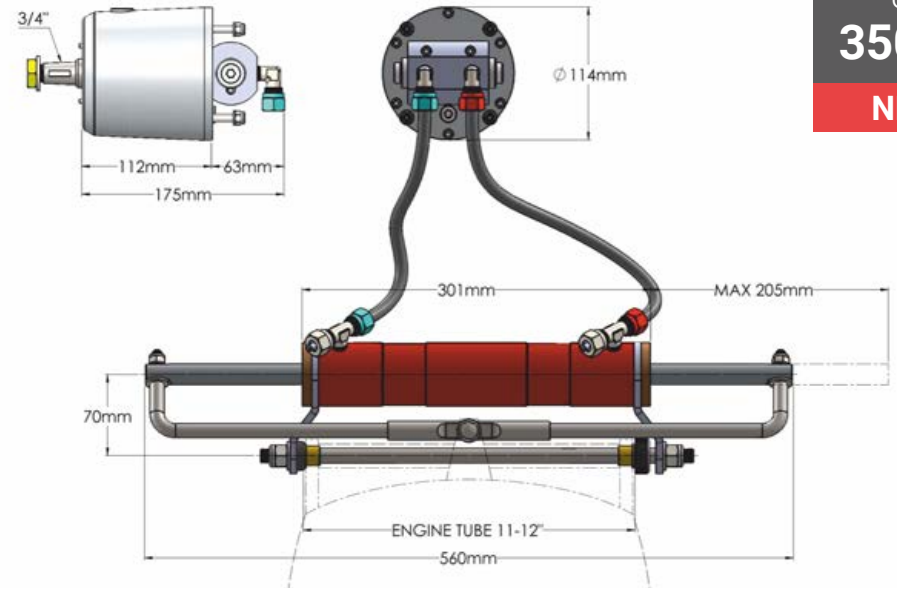

UP TO  
**350HP**

**NEW**



## Pump: TL2 Front mounting

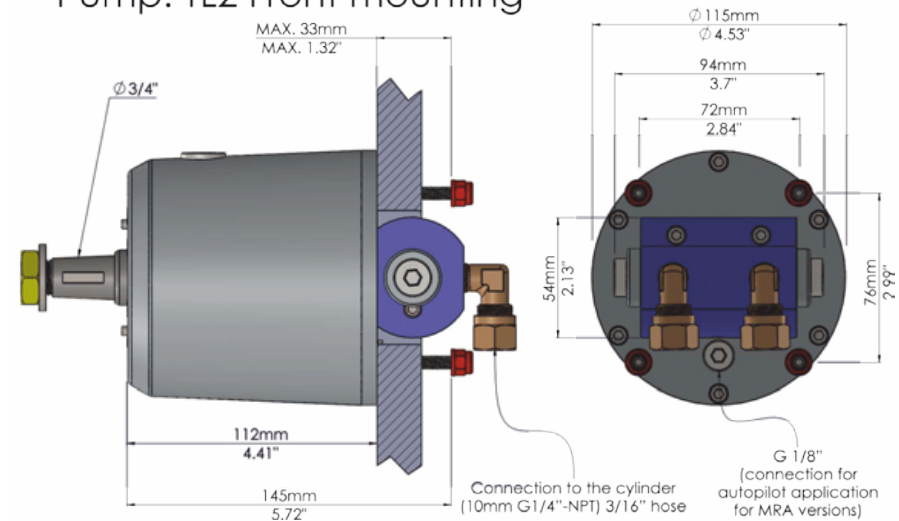

# MF350W-TDF

For twin outboards up to  
300 + 300HP



SPECIFICATIONS	
AMI Code	0210158
Supplier Code	MF350W-TDF
Engine Power (Max)	300 + 300HP
Output Force	2 x 495 Kgf
Torque	2 x 102 Kgm
Max Speed	75 Kts
Turns	7.2
Lock Valve	Yes
Cylinder	2 x MC350-W 146cc 206mm stroke
Hose Set	Twin 7.0m + 7.0m (23')
Hose Set	Twin 0.75m + 0.75m (2.5')
Autopilot Capable	Yes

Kits Include 3L of Hydraulic Oil.  
No steering wheel included.  
New Stainless Steel Twin Engine Arm included.

## Built in non feedback valve Automatic Pilot Connection Port

- Extremely easy to install
- Pump made from full hardened aluminium
- Cylinder made from cold drawn, hardened aluminium
- High pressure Hose Set (1700 PSI - 120 bar)
- Universal application



New Stainless - Steel Twin Engine Arm included

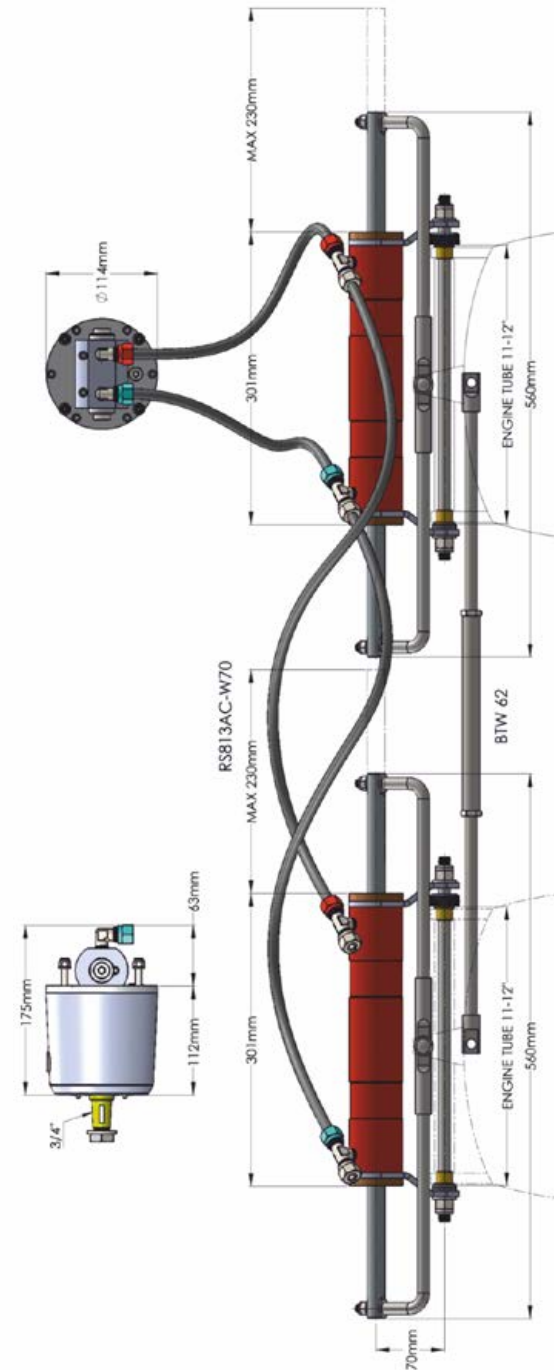

TWIN  
OUTBOARDS  
MAX  
**300  
+300HP**  
**NEW**

# Designed for Quality

## Superior quality at all levels of design and manufacture

- ✓ Helm pumps are manufactured from a single aluminium block, hardened and hot pressed. The 10mm thickness and aircraft industry based material prevents oil film/fog forming, even under high pressure.
- ✓ Quality 3 ball bearing pumps ensures outstanding precision and exceptionally smooth and consistent operation.
- ✓ Helm pumps are both anodised and painted, giving the best protection against the highly corrosive marine environment.
- ✓ Cylinders are cold drawn, hardened aluminium and are anodised and painted for superior corrosion resistance.
- ✓ Twin tube hydraulic hoses are pre-fitted allowing for complete ease of installation.
- ✓ Strict quality control throughout the entire manufacturing process ensures the highest product quality.
- ✓ Universal fittings allow Hydrodrive to be used on every type of outboard engine.

**Hydrodrive is imported into Australia by AMI Sales**

**[www.amisales.com.au](http://www.amisales.com.au)**

Your local Hydrodrive Dealer: